

Fixing Guide

INTRAD RA2 (Option 01)



General Information

INTRAD materials should be stored flat and protected against damage. Allow 24 hours for materials to reach ambient room temperature.

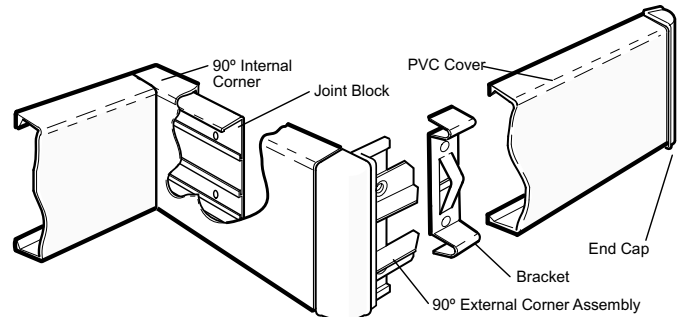

STEP 1

Mark out wall at required height.

STEP 2

Screw fix corner adapter to end cap using fixings provided - Fig 1

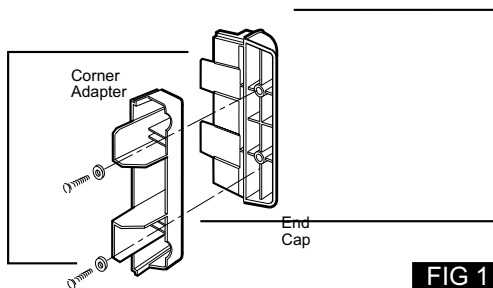

FIG 1

STEP 3

Screw fix end caps and 90 degree corners to wall using appropriate fixing and washer - (see fixing guide)

STEP 4

Establish location of butt joints (standard profile length 3m)
Screw fix jointing piece centrally to location of butt joint - Fig 2
Screw fix jointing piece to either side of an internal corner formed with a butt joint.

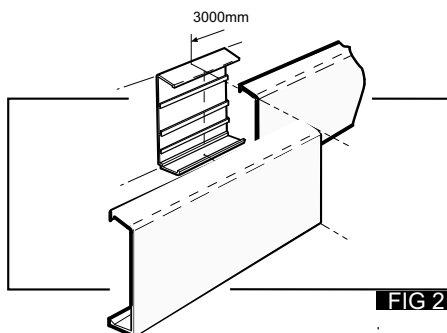

STEP 5

Screw fix brackets at wall at maximum 600mm centres - Fig 3
Screw fix brackets 100mm from each end.
Use appropriate fixings together with washers (See fixing guide)

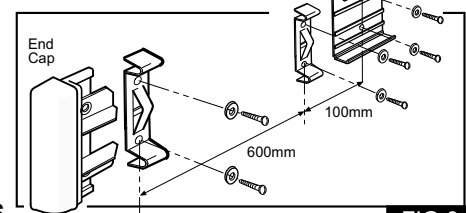

FIG 3

STEP 6

Cut PVC cover to size.
Ensure joints align with joint blocks previously installed.
Form internal corners as butt joints - Fig 4
Ensure cuts are square and free from burr.

STEP 7

Factory formed 90 degree (or other degree) angles must be fitted over joint blocks (both sides) - Fig 5

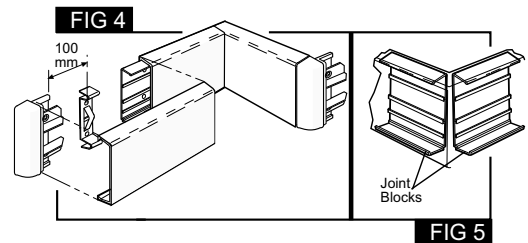

FIG 5

Note: Lengths of extrusion are cut in the factory on a continuous production line. Cuts cannot be assumed to be square or free from burr.

The Fixings listed are those recommended by INTRAD. Should alternatives be used it is the responsibility of the installer to ensure they are of suitable specification.