

Specification INTRAD RCR-200



Product Description

A combined hand and crash-rail system for heavy traffic areas. INTRAD RCR-200 combines a warm touch handrail, décor strip (supplied in the same or contrasting colours), a high impact crash rail and both tactile end and corner mouldings for the visually impaired.

INTRAD RCR-200 has been developed and designed to fulfil a unique combination of functions. It is an ergonomic handrail, providing a comfortable and secure handgrip. It will withstand impact and wear to prolong and protect your interiors from damage and wear.

Product Reference

INTRAD RCR-200, comprising of a continuous aluminium core & impact absorber, cover and spacers.

NBS

P20/161 proprietary crash-rail and handrail.

Size

200(H) x 95(D) mm

Impact Rating

Heavy to Severe Duty

Colour/Finish

To be selected from the manufacturer's available colour range. Handrail and buffer have a lightly embossed finish which is warm to the touch.

Accessories

Wall Return
90° Corner Angle

Manufacturer

PJP Limited, 184 St. Albans Road West, Hatfield, Hertfordshire, AL10 0TF, United Kingdom.

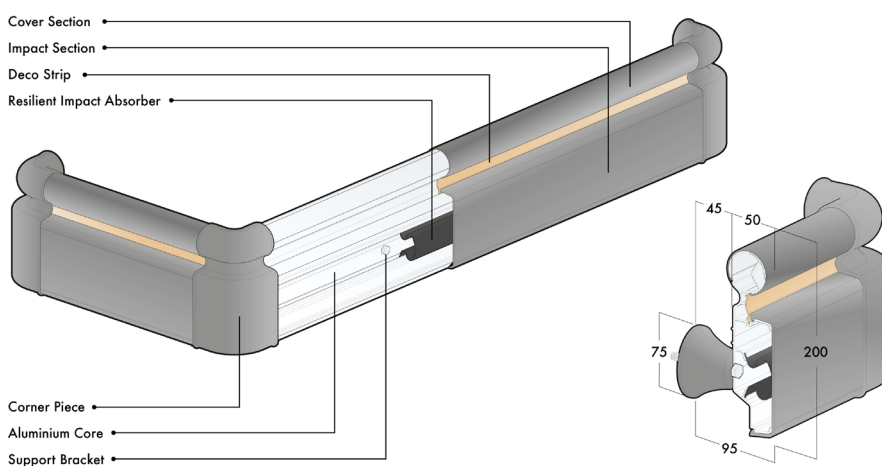

Note

If the INTRAD RCR-200 is to be fitted to hollow walls (single/double skin plasterboard systems or similar) a suitable continuous noggin, pattress or metal channel must be installed.