

Specification INTRAD RCR-125



Product Description

A combined hand and crash-rail system in a compact and integrated design. INTRAD RCR-125 combines a smooth handgrip, embossed impact zone (to give increased durability) and both tactile end and corner mouldings for the visually impaired.

INTRAD RCR-125 is an ergonomic handrail, providing a comfortable and secure handgrip whilst the robust design is capable of withstanding impact and wear experienced from main corridors.

Product Reference

INTRAD RCR-125, comprising of a continuous aluminium core & impact absorber, cover and spacers.

NBS

P20/161A proprietary crash-rail and handrail.

Size

125(H) x 95(D) mm

Impact Rating

Heavy to Severe Duty

Colour/Finish

To be selected from the manufacturer's available colour range. Handrail section is smooth and warm to the touch with an embossed impact area.

Accessories

Wall Return
90° Corner Angle

Manufacturer

PJP Limited, 184 St. Albans Road West, Hatfield, Hertfordshire, AL10 0TF, United Kingdom.

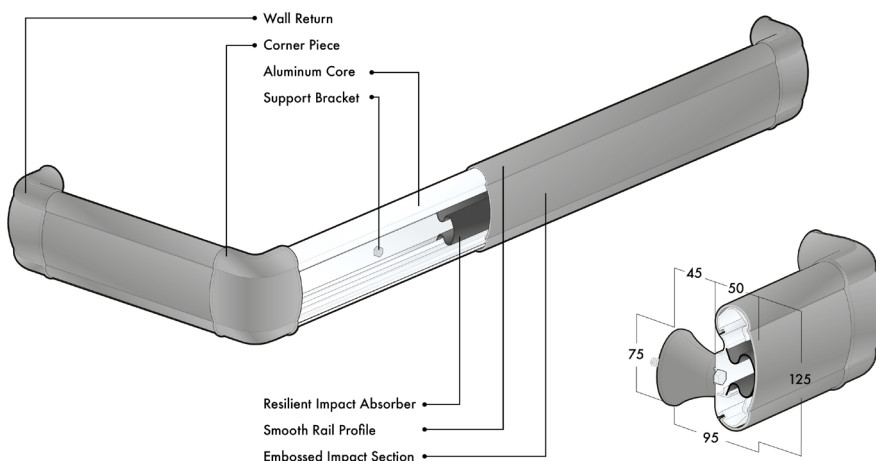

Note

If the INTRAD RCR-125 is to be fitted to hollow walls (single/double skin plasterboard systems or similar) a suitable continuous noggin, pattress or metal channel must be installed.